

SUM TOTAL EXTENSION OF LUFF POCKET (A+B) SHALL NOT BE GREATER THAN 100mm PAST HEAD AND TACK MEASUREMENT POINTS.

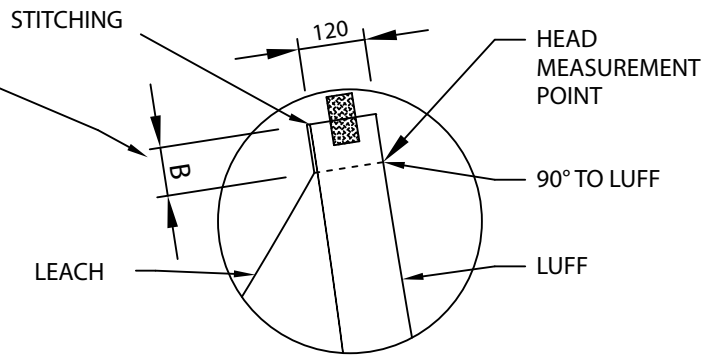

NOTE

1. CORNER REINFORCING AS PER 9.2.4
2. WINDOW SIZE & PLACEMENT AS PER 9.2.5
3. INSIGNIA & SAIL NUMBERS AS PER 9.3
4. BATTENS AS PER 9.4

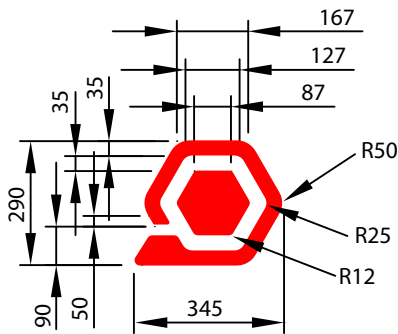

SPIRAL INSIGNIA

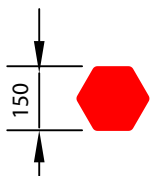

5.6 M² INSIGNIA

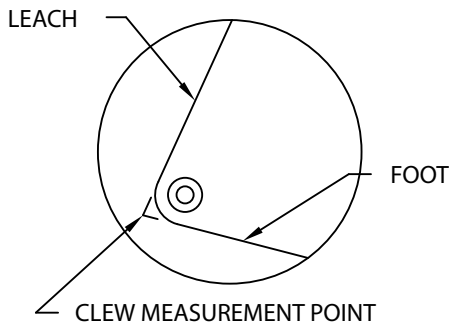
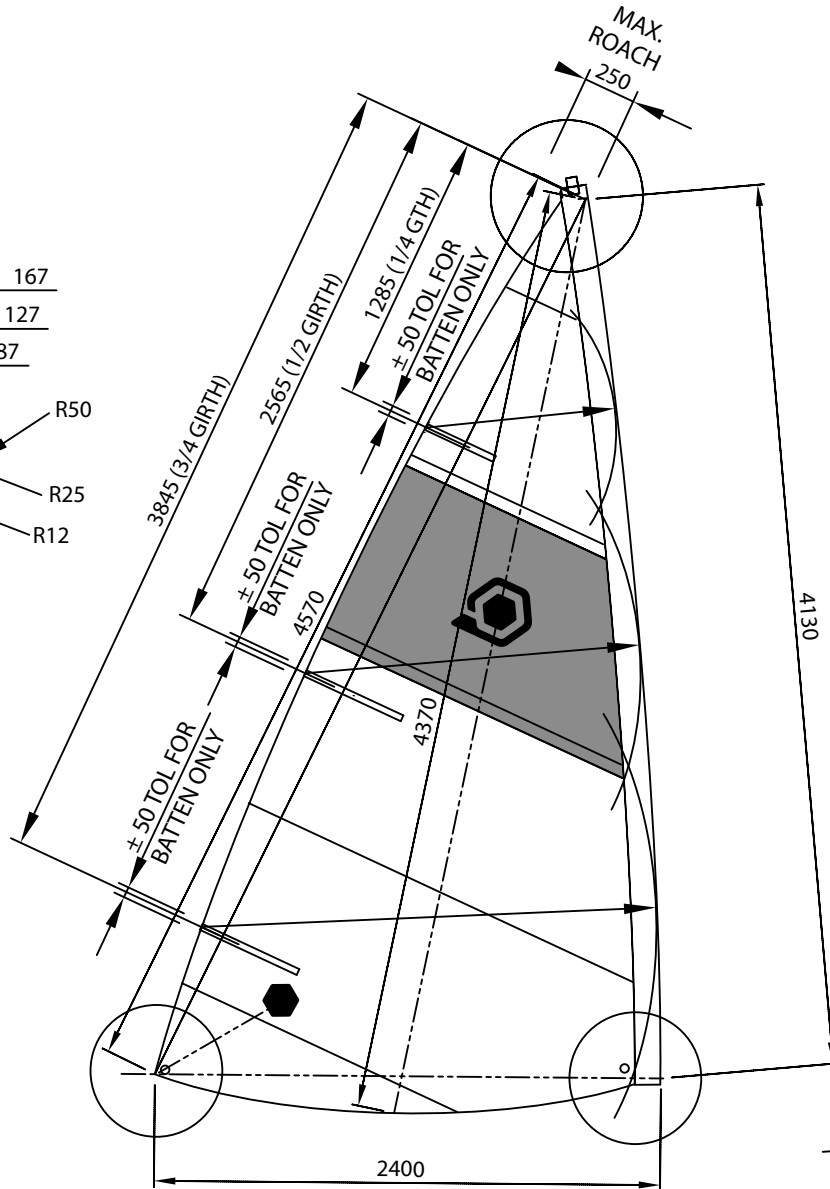

CLEW MEASUREMENT POINT

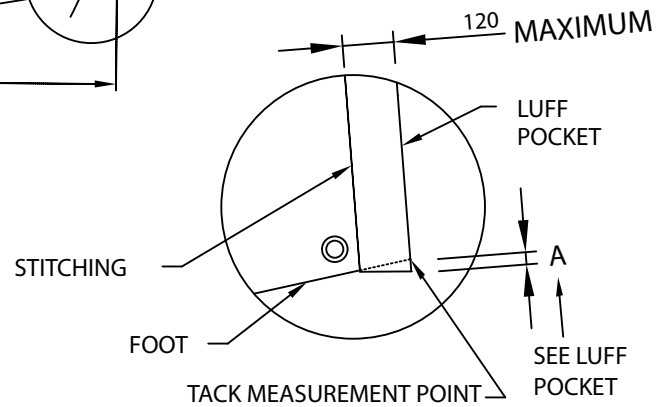

SEE LUFF POCKET EXTENSION NOTE

“SHORT MAST” 5.6 M² SAIL PLAN

(TO BE READ IN CONJUNCTION WITH RULE 9 AND FIG. 8)

FIG.9A

“SHORT MAST” 5.6 M² SAIL PLAN